

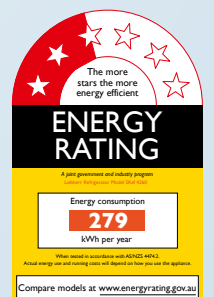

Freshness For
Healthy Living

Quality, Design and Innovation

SKef 4260



LIEBHERR



SmartSteel: With SmartSteel used on the appliance door the visibility of fingerprints is reduced, making it very easy to clean. Maintain this beautiful door exterior simply with a wipe of a clean, dry or damp cloth.



Touch control system: Our intuitive electronic touch control panel ensures all functions are easy and convenient to use as well as guarantees that the settings selected remain accurate and constant.



of the refrigerator to +2°C for 6 hours (switching back to normal operation automatically). By activating prior to grocery shopping, it will assist with cooling the new food more rapidly, thereby prolonging food preservation.

Liebherr's **SKef 4260** fridge includes 2 fruit and vegetable drawers on telescopic rails, adjustable GlassLine shelving plus SuperCool.

With the fruit and vegetable crispers positioned on telescopic rails it allows for smooth and easy access to the contents within. Another feature which assists in effortless access is the integrated opening device fitted to the handle. Even if recently closed, the device gently applies pressure to the seal, allowing the door to easily open.

It is important to note that if pairing with another model it will only match the SGNef 3036.

SKef 4260	
Comfort	Smart Steel
Energy consumption (kWh/yr) Star rating	279 2.5
Compressors	1
Total Usable Litres	381
Refrigerator Usable Litres	381
Control system Display	Touch-Electronics LCD
Child proof setting for display & temperature	•
LED standard lighting	•
Handle design	Aluminium
Integrated opening device	•
Malfunction warning signal Door open warning signal	•
Fruit & vegetable drawer on pull-out rails	2
SuperCool	•
GlassLine shelves	•
Elegant holding columns	•
Egg tray	•
Automatic refrigerator defrosting	•
Door hinges	Right
Voltage (V) Rated Current (A)	220-240 1.2
Made in	Bulgaria

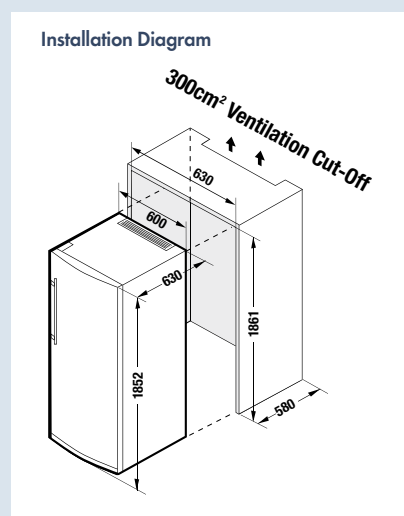

Note: Whilst every effort is made to ensure all specifications and information in this flyer are accurate, Liebherr reserves the right to make changes without notification. Where actual appliance measurements, specifications, and ratings are crucial, we recommend that the actual appliance installation instructions that accompany each appliance be checked. Liebherr will not be liable for any loss.