

GE
Appliances

Refrigeration

GE Asia 2010



GE imagination at work

Side-by-Side

Refreshment Centre



The refreshment centre provides easy external access to foods and drinks stored inside the refrigerator door.

QuickChill Function

For faster freezing or refrigerator cooling, the QuickChill function can be activated via the control panel.

Child Lock



Use this function to lock the control panel ensuring that selected temperatures are not varied accidentally or ice and water dispensed when not required.



Ice & Water Dispenser

The ice & water dispenser is perfect for entertaining. It allows convenient dispensing of water, cubed ice and crushed ice at the touch of a button.

DeliFresh Compartment

Provides a temperature controlled environment for fresh food.

SelectTemp™ Drawer



Keeps meats, fruits and vegetables cool and crisp. It creates the ideal environment for maintaining freshness by controlling temperature and air flow.

GE Water Filtration

Removing impurities adds a fresher taste to your families water.

Interior Lighting

Refrigerators feature interior lighting making it easier to view the contents inside.

Wine Rack



The wine rack provides the perfect storage space for up to 4 bottles of wine or sparkling.

Tilting Freezer Door Bins

Freezer door bins tilt forward to give full access to food items no matter how food has been packed.

Not all features available on all models. Please see the product specifications for details.



Model: GCU200NHWCIS
Colour: Inox silver finish
Cabinet colour: Grey
Configuration: Counter depth
Total gross capacity (litres): 604

Main features:

- Refreshment centre
- Ice & water dispenser
- 3 tempered glass shelves
- DeliFresh compartment
- SelectTemp™ drawer
- 2 humidity controlled crisper bins
- 1 door gallon storage bin
- Electronic exterior controls
- Coloured LED display
- QuickChill function
- Child lock
- Water filter indicator
- Door alarm
- Interior light in fridge and freezer
- Freshsaver deodoriser

Also available in a white textured finish (GCU200NHWCWW) with aluminium handles



Model: GCU200NGWCIS
Colour: Inox silver finish
Cabinet colour: Grey
Configuration: Counter depth
Total gross capacity (litres): 604

Main features:

- Ice & water dispenser
- 3 tempered glass shelves
- DeliFresh compartment
- SelectTemp™ drawer
- 2 humidity controlled crisper bins
- 1 door gallon storage bin
- Electronic exterior controls
- Coloured LED display
- QuickChill function
- Child lock
- Water filter indicator
- Door alarm
- Interior light in fridge and freezer
- Freshsaver deodoriser

Also available in a white textured finish (GCU200NGWCWW) with aluminium handles



Model: GCU200YAWCIS
Colour: Inox silver finish
Cabinet colour: Grey
Configuration: Counter depth
Total gross capacity (litres): 618

Main features:

- 4 tempered glass shelves
- 2 humidity controlled crisper bins
- Chiller compartment
- Clear dairy bin
- 4 door shelves
 - including 2 door gallon storage bins
- 2 ice trays
- Interior electronic controls
- LED display
- Door alarm
- Interior light in fridge and freezer
- Freshsaver deodoriser

Also available in a white textured finish (GCU200YAWCWW) with aluminium handles

Model Number	GCU200NHWCIS	GCU200NHWCWW	GCU200NGWCIS	GCU200NGWCWW	GCU200YAWCIS	GCU200YAWCWW
Total capacity - Gross / Net (litres)	604 / 518	604 / 518	604 / 518	604 / 518	618 / 555	618 / 555
Fresh food - Gross / Net (litres)	377 / 343	377 / 343	377 / 343	377 / 343	377 / 354	377 / 354
Freezer - Gross / Net (litres)	227 / 175	227 / 175	227 / 175	227 / 175	241 / 201	241 / 201
FRESH FOOD FEATURES						
SelectTemp™ drawer	•	•	•	•	–	–
DeliFresh compartment Chiller compartment	1 –	1 –	1 –	1 –	– 1	– 1
Humidity controlled crisper bins	Clear, 2 sealed	Clear, 2 sealed	Clear, 2 sealed	Clear, 2 sealed	Clear, 2 sealed	Clear, 2 sealed
Wine rack	1 full	1 full	1 full	1 full	–	–
Egg bin	•	•	•	•	•	•
Freshsaver deodoriser	1	1	1	1	1	1
Interior light	Top	Top	Top	Top	Top	Top
Tempered glass cabinet shelves Adjustable	3 2	3 2	3 2	3 2	4 3	4 3
Top pan cover	Glass	Glass	Glass	Glass	Glass	Glass
Refrigerator door						
Dispenser	Water and ice	Water and ice	Water and ice	Water and ice	–	–
Refreshment centre door	•	•	–	–	–	–
Standard door bins	3 fixed / 1 covered	3 fixed / 1 covered	4 fixed	4 fixed	4 fixed	4 fixed
Door gallon storage	1	1	1	1	2	2
Dairy bin	Clear	Clear	Clear	Clear	Clear	Clear
FREEZER FEATURES						
Interior light	40W frosted	40W frosted	40W frosted	40W frosted	40W frosted	40W frosted
Fixed shelves Adjustable shelves	1 2	1 2	1 2	1 2	1 3	1 3
Bins and features	2 full basket	2 full basket	2 full basket	2 full basket	2 full basket	2 full basket
Automatic ice maker Ice trays	• –	• –	• –	• –	– 2	– 2
Fixed freezer door bins Tilting freezer door bins	1 3	1 3	1 3	1 3	5 –	5 –
CONTROLS # Water quality and taste may alter if filters are not replaced when recommended by the water filter indicator light.						
Electronic control location	Outside / on door	Outside / on door	Outside / on door	Outside / on door	Inside	Inside
Display / indications	Coloured LED display	Coloured LED display	Coloured LED display	Coloured LED display	LED display (indoor)	LED display (indoor)
Functions – QuickChill	•	•	•	•	–	–
Child lock Door alarm	• •	• •	• •	• •	– •	– •
Water filter indicator*	•	•	•	•	–	–
EXTERIOR						
Finish of doors	Inox silver	White textured finish	Inox silver	White textured finish	Inox silver	White textured finish
Handles	Aluminium long bar	Aluminium long bar	Aluminium long bar	Aluminium long bar	Aluminium long bar	Aluminium long bar
Control panel colour Refreshment centre panel colour	Grey Silver half panel	Silver Silver half panel	Grey –	Silver –	– –	– –
Dispenser colour - Recess Paddle Trim	Grey Grey Silver	White Grey White	Grey Grey Silver	White Grey White	– – –	– – –
WEIGHTS & DIMENSIONS						
Overall height (mm) / depth (mm) / width (mm)	1790 / 730 / 895	1790 / 730 / 895	1790 / 730 / 895	1790 / 730 / 895	1790 / 730 / 895	1790 / 730 / 895
Case depth without door (mm) / Depth with door (mm)	600 / 670	600 / 670	600 / 670	600 / 670	600 / 670	600 / 670
Depth with door open 90° (mm)	1137	1137	1137	1137	1137	1137
Air clearance on each side (mm) / top (mm) / back (mm)	20 / 50 / 50	20 / 50 / 50	20 / 50 / 50	20 / 50 / 50	20 / 50 / 50	20 / 50 / 50
Product weight (kg)	117	117	115	115	104	104
FUNCTIONAL CHARACTERISTIC						
Power (W / Hz)	220-240 / 50	220-240 / 50	220-240 / 50	220-240 / 50	220-240 / 50	220-240 / 50
Energy consumption (kWh / year)	760	760	760	760	650	650
Star rating MEPS 2005 / Star rating MEPS 2010	3.5 / 1.5	3.5 / 1.5	3.5 / 1.5	3.5 / 1.5	4 / 2	4 / 2
Freezing capacity (kg / 24hr)	10	10	10	10	10	10
Sound power (dBa)	44	44	44	44	44	44

Top-Freezer



NoFrost

No frost technology reduces freezer burn.

Side Air Flow

Side air flow delivers cold air throughout the interior for better cooling.

Temperature Controls

Individual temperature controls in the fridge and freezer allow you to set the desired temperature easily.

Tempered Glass Shelves

Adjustable slide-out shelves provide storage flexibility and ease of use – benefits every customer appreciates.

Clear Storage Bins

Allows easy viewing of refrigerator contents, while giving the interior a brighter, more open appearance.

Meat Keeper Tray

The meat keeper tray with shutter provides the perfect environment for fresh meats.

Triple Twist Ice Cube Tray

The triple twist ice cube tray ensures cubed ice is readily available and conveniently stored.

Humidity Controlled Crisper Bin

Provides the ideal storage environment, keeping fruits and vegetables crisp and fresh.

Vitamin C Filter

Reduces moisture loss in the crisper.

UV-LED Deodoriser

Inside the refrigerator compartment, UV-LED plus platinum beam deodoriser system eliminates bacteria that causes decomposition in food. This system operates when the refrigerator door is opened and continues for five minutes after the refrigerator door is closed.

Interior Lighting

Interior lighting provides greater visibility. Freezer dome light distributes light evenly in the freezer compartment.

Not all features available on all models. Please see the product specifications for details.



Model: GTU180PAXRSS
Colour: Stainless steel
Cabinet colour: Grey
Configuration: Standard depth
Total gross capacity (litres): 574

Main features:

No frost with side air flow
3 tempered glass shelves
Humidity controlled crisper bin
Meat keeper tray
Egg pockets 24 piece
2 bottle shelves
4 half width door shelves
Triple twist ice cube tray
Electronic freezer temperature controls
Platinum charcoal filter deodoriser
Anti bacteria UV-LED / platinum beam
Vitamin C filter
Interior light in fridge and freezer
Stainless steel bar handles

Also available in white (GTU180PAXRWW) with stainless steel bar handles



Model: GTU150PAXRSS
Colour: Stainless steel
Cabinet colour: Grey
Configuration: Standard depth
Total gross capacity (litres): 475

Main features:

No frost with side air flow
3 tempered glass shelves
Humidity controlled crisper bin
Meat keeper tray
Egg pockets 12 piece
2 bottle shelves
2 full width door shelves
Triple twist ice cube tray
Electronic freezer temperature controls
Platinum charcoal filter deodoriser
Anti bacteria UV-LED / platinum beam
Vitamin C filter
Interior light in fridge and freezer
Stainless steel bar handles

Also available in white (GTU150PAXRWW) with stainless steel bar handles

Model Number	GTU180PAXRSS	GTU180PAXRWW	GTU150PAXRSS	GTU150PAXRWW
Total capacity - Gross / Net (litres)	574 / 476	574 / 476	475 / 394	475 / 394
Fresh food - Gross / Net (litres)	384 / 327	384 / 327	322 / 274	322 / 274
Freezer - Gross / Net (litres)	190 / 149	190 / 149	153 / 120	153 / 120
FRESH FOOD COMPARTMENT				
Refrigerator fan motor	AC	AC	AC	AC
Meat keeper tray Meat keeper tray shutter	1 1	1 1	1 1	1 1
Adjustable glass shelves	2	2	2	2
Humidity controlled crisper bin Glass crisper shelf	1 1	1 1	1 1	1 1
Egg pocket	2 (24 pcs)	2 (24 pcs)	1 (12 pcs)	1 (12 pcs)
Refrigerator door utility rack (full)	-	-	2	2
Refrigerator door utility rack (half)	4	4	-	-
Bottle rack	2	2	2	2
Refrigerator interior lamp	•	•	•	•
Front drain tray	•	•	•	•
Kick plate	•	•	•	•
FREEZER FEATURES				
Twist ice tray	Triple	Triple	Triple	Triple
Ice cube box	1	1	1	1
Freezer shelf	1	1	1	1
Freezer door full rack	2	2	2	2
Freezer lamp	•	•	•	•
Freezer fan motor	DC	DC	DC	DC
OTHER FEATURES				
Deodoriser	Platinum charcoal filter	Platinum charcoal filter	Platinum charcoal filter	Platinum charcoal filter
Anti bacteria	UV-LED / Platinum beam	UV-LED / Platinum beam	UV-LED / Platinum beam	UV-LED / Platinum beam
Vitamin C filter	•	•	•	•
Side air flow	•	•	•	•
Refrigerant	R-134a	R-134a	R-134a	R-134a
Insulation	Cyclopentane	Cyclopentane	Cyclopentane	Cyclopentane
Temperature control - Freezer	Electronic	Electronic	Electronic	Electronic
Temperature control - Refrigerator	Thermo damper	Thermo damper	Thermo damper	Thermo damper
Defrosting	Electronic time defrost	Electronic time defrost	Electronic time defrost	Electronic time defrost
Colour	Stainless steel	White	Stainless steel	White
Handles	Stainless steel bar	Stainless steel bar	Stainless steel bar	Stainless steel bar
WEIGHTS & DIMENSIONS				
Overall height (mm) Overall width (mm)	1780 798	1780 798	1715 727	1715 727
Case depth without door (mm)	627	627	655	655
Case depth with door less door handle (mm)	710	710	735	735
Case depth with door incl. door handle	717	717	755	755
Depth with door open 90° (mm)	1445	1445	1440	1440
Air clearance - each side (mm) / top (mm) / back (mm)	60 / 300 / 60	60 / 300 / 60	60 / 300 / 60	60 / 300 / 60
Product weight (kg)	91	91	80	80
FUNCTIONAL CHARACTERISTIC				
Power (V/Hz)	220-240/50	220-240/50	220-240/50	220-240/50
Energy consumption (kWh / year)	506	506	509	509
Star rating MEPS 2005 / Star rating MEPS 2010	4.5 / 2.5	4.5 / 2.5	4.0 / 2.5	4.0 / 2.5
Freezing capacity (kg / 24hrs)	7	7	6	6
Sound power (dBa)	42	42	42	42

Dimensions

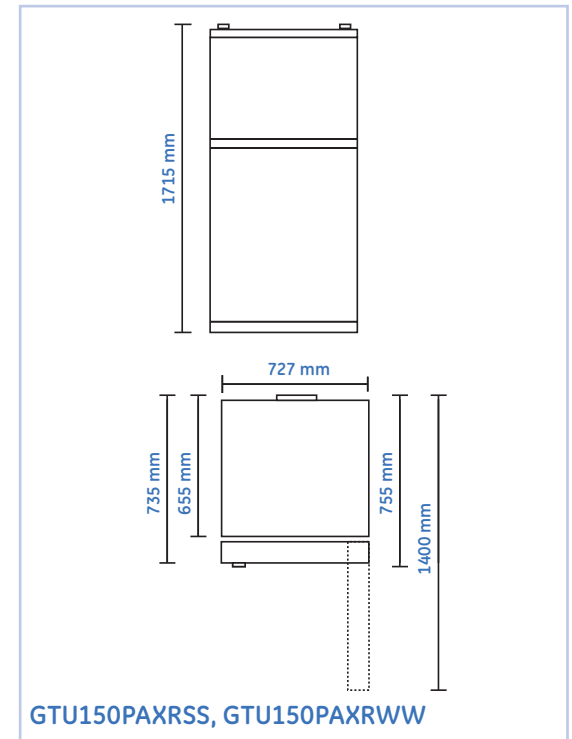
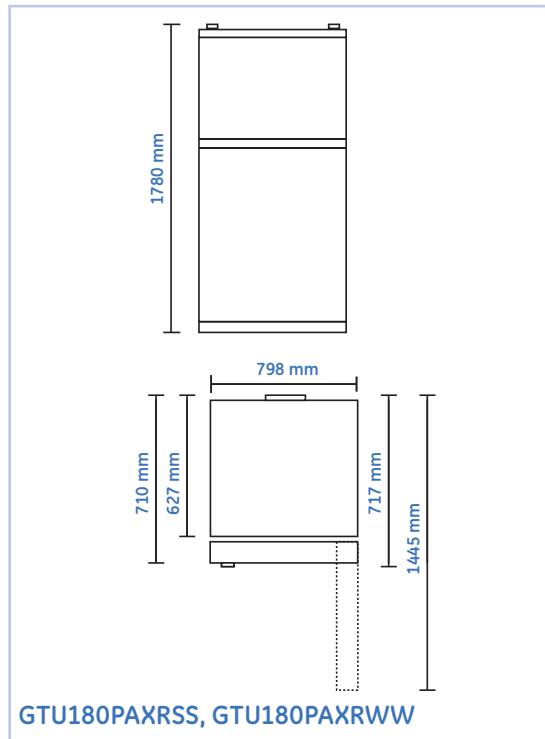
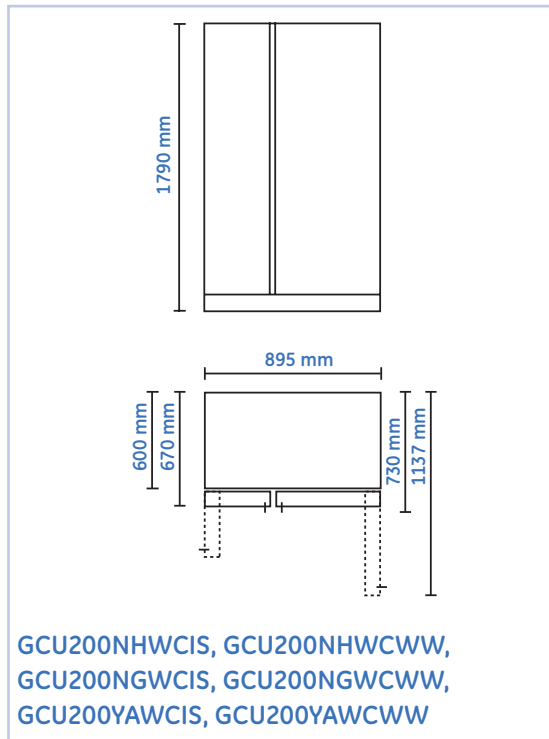

Andi-Co Australia Customer Care

Warranty

- » For two (2) years from date of original purchase we will provide free of charge parts and labour service in your home to repair or replace *any part of the refrigerator* that fails because of a manufacturing defect.
- » For five (5) years from date of original purchase we will also provide free of charge parts and labour in your home to repair or replace *any part of the sealed system* (the compressor, condenser, evaporator and all connecting tubing) that fails because of a manufacturing defect.

Customer care

Our National Customer Care Centre can be contacted should you require instruction or service. A local call charge 1300 line allows you from across Australia to directly dial for assistance. Our extensive service network covers most areas of Australia. Tel: 1300 650 020

Spare parts direct

To order spare parts or accessories, please call our Spare Parts Office
Tel: (03) 9569 7744 Fax: (03) 9569 1650



GE imagination at work

Victoria
Head office
1 Stamford Road
Oakleigh VIC 3166
T: (03) 9569 1255
F: (03) 9569 1450

South Australia
DM Agencies Pty Ltd
Adelaide SA
F: (08) 8325 1005
E: dmagencies@bigpond.com.au

Western Australia
JH Wilberforce (Agent)
37 Clune Street
Bayswater WA 6053
T: (08) 9340 6222
F: (08) 9340 6262

Whilst every effort is made to ensure all specifications and information in our brochure is correct at time of printing, Andi-Co Australia Pty Ltd reserve the right to make changes without notification. Where actual appliance measurements, specifications and ratings are crucial we recommend that the actual appliance instructions that accompany each appliance be checked. Andi-Co Australia Pty Ltd ABN 68 005 899 365 will not be liable for any loss arising from the information in this brochure, whether in negligence or otherwise. Brochure is revised by BizziBee Graphic Design for Andi-Co Australia Pty Ltd.